

VICINITY MAP
SCALE: NTS

DEVELOPMENT SUMMARY	
ZONING	
EXISTING ZONING	LJ
PROPOSED ZONING	PLD-R
AREA	
SITE AREA	20.48 ACRES
OPEN SPACE	5.36 ACRES (26.1%)
DENSITY	
RECREATION AREA REQUIRED (1 AC/50 LOTS)	2.20 ACRES
RECREATION AREA PROVIDED (INCLUDING PONDS)	2.20 ACRES
50' WIDE SINGLE FAMILY DETACHED LOTS	48 UNITS
35' WIDE SINGLE FAMILY DETACHED LOTS	31 UNITS
TOWNHOMES	33 UNITS
TOTAL NUMBER OF UNITS	110 UNITS
PROPOSED DENSITY	5.4 UNITS/ACRE
SETBACKS	
FRONT	5 FEET
SIDE	5 FEET
SIDE MAJOR	5 FEET
REAR	10 FEET
PERIMETER	35 FEET
MAXIMUM BUILDING HEIGHT	35 FEET

- NOTES:
1. PROPOSED USE: SINGLE FAMILY DWELLINGS.
 2. SITE AREA: 20.48 ACRES.
 3. UTILITY LOCATION AND EASEMENTS TO BE DETERMINED.
 4. DUMPSTER NOT APPLICABLE FOR SUBDIVISION.
 5. EXISTING GRADES ARE SHOWN.
 6. NO PARKING LOTS PROPOSED FOR THIS PROJECT EXCEPT MAIL KIOSK AND THE AMENITY CENTER/RECREATION AREA.
 7. LANDSCAPING TO BE DETERMINED.
 8. THIS SITE DOES LIE WITHIN ZONE X AS INDICATED ON FEMA FIRM PANEL 1306700181H DATED MARCH 4, 2013.

24 HOUR CONTACT:
JEFF SMITH
404.328.6280

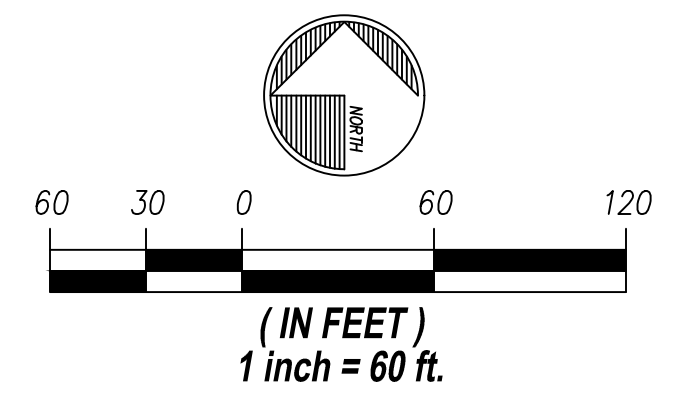

THE UTILITIES SHOWN HEREON ARE FOR THE CONTRACTORS CONVENIENCE ONLY. THERE MAY BE OTHER UTILITIES NOT SHOWN ON THESE PLANS. THE ENGINEER ASSUMES NO RESPONSIBILITY FOR THE LOCATIONS SHOWN AND IT SHALL BE THE CONTRACTOR'S RESPONSIBILITY TO VERIFY ALL UTILITIES WITHIN THE LIMITS OF THE WORK. ALL DAMAGE MADE TO EXISTING UTILITIES BY THE CONTRACTOR SHALL BE THE SOLE RESPONSIBILITY OF THE CONTRACTOR.

RIDGE PLANNING AND ENGINEERING®
1290 KENNESTONE CIRCLE - BLDG A
SUITE 200 - MARIETTA, GA 30066
OFFICE 770.938.9000

ZONING PLAN
OLD LOST MOUNTAIN RD
LAND LOTS LAND LOT 727
19th DISTRICT, 2ND SECTION
CITY OF POWDER SPRINGS, GEORGIA

OWNER/DEVELOPER
TRATON HOMES
750 CHASTAIN CORNER RD
MARIETTA, GEORGIA 30066

GSWCC CERTIFICATION NUMBER: 36629
EXPIRATION DATE: 08.01.2018



REVISIONS
1. 6/1/20 - REVISE ZONING PLAN

ZONING PLAN
Z100