

SITE STAKING LAYOUT NOTES:

- A. BOUNDARY INFORMATION TAKEN FROM SURVEY BY MATTHEW WILSON, GA. R.L.S. #2728.
- B. TOTAL AREA OF SITE = 2.05 ACRES
- C. PARKING SPACES PROVIDED = 31, PARKING SPACES REQUIRED = 6
- D. BUILDING = 3,850 SQUARE FEET. SINGLE STORY.
- E. ALL CONSTRUCTION SHALL CONFORM TO POWDER SPRINGS STANDARD SPECIFICATIONS AND REGULATIONS.
- F. PERSONS USING THIS DRAWING SHOULD CONTACT LOCAL UTILITY COMPANIES FOR EXACT LOCATIONS OF UNDERGROUND UTILITIES.
- G. ALL DIMENSIONS ARE TO FACE OF CURB, FACE OF BUILDING, FACE OF WALK, ETC. UNLESS OTHERWISE NOTED.
- H. ALL RADIUS 5' UNLESS OTHERWISE NOTED.
- I. SEE ARCHITECTURAL DRAWINGS FOR EXACT BUILDING DIMENSIONS.
- J. DO NOT SCALE FROM THIS DRAWING. WRITTEN DIMENSIONS PREVAIL.
- K. PRESENT ZONING = CRC-COMMUNITY RETAIL COMMERCIAL.
- L. ALL ANGLES 90° UNLESS OTHERWISE NOTED.

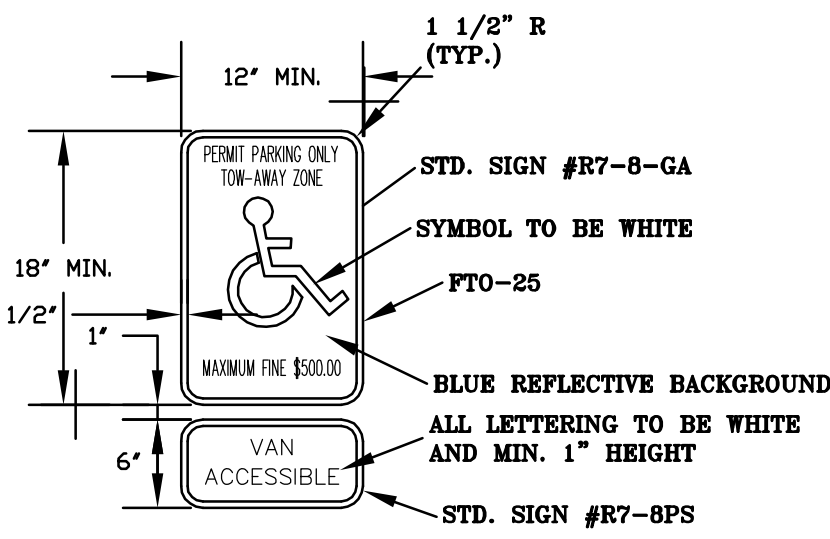

- NOTES:**
- ALL SIGNS TO BE 0.080" THICK ALUMINUM.
  - ALL SIGNS SHALL CONFORM WITH ALL CURRENT A.D.A. FEDERAL, STATE, AND LOCAL CODES AND REGULATIONS.
  - PLACE "VAN-ACCESSIBLE" SIGN IN FRONT OF VAN ACCESSIBLE SPACES ONLY

HANDICAP SYMBOL

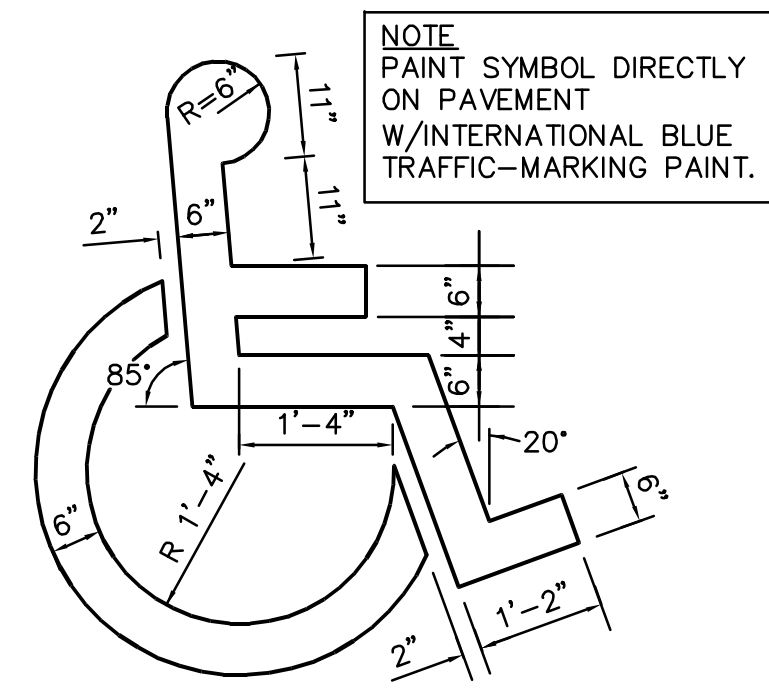

24" CURB AND GUTTER

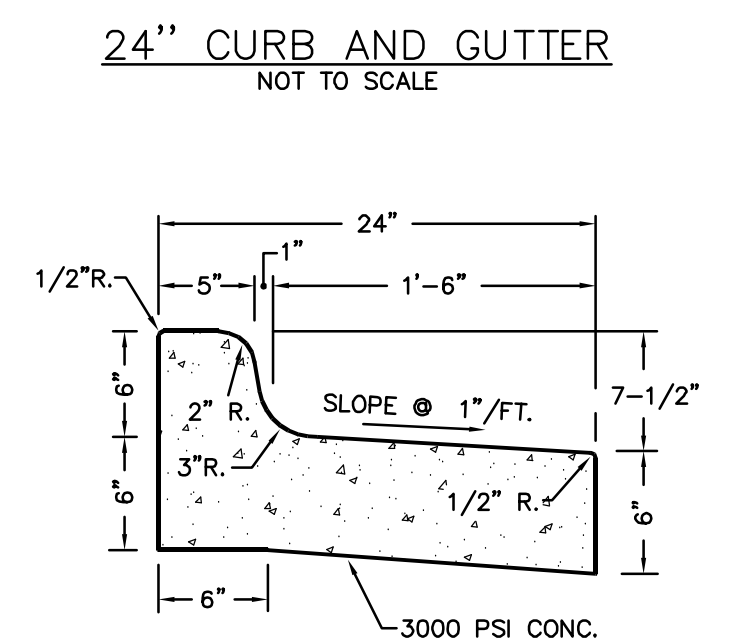
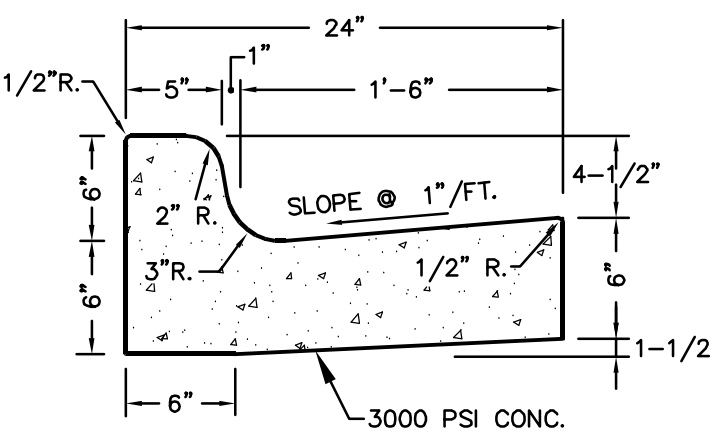

24" PITCHED CURB AND GUTTER

**DEVELOPMENTAL DATA:**

- TOTAL AREA OF SITE: ±2.05 ACRES
- SIZE OF BUILDING: 3,850 SF.
- SETBACKS: FRONT-50  
SIDE-20  
REAR-25
- PARKING REQUIREMENTS:  
REQUIRED PARKING- 6  
PROPOSED PARKING- 31

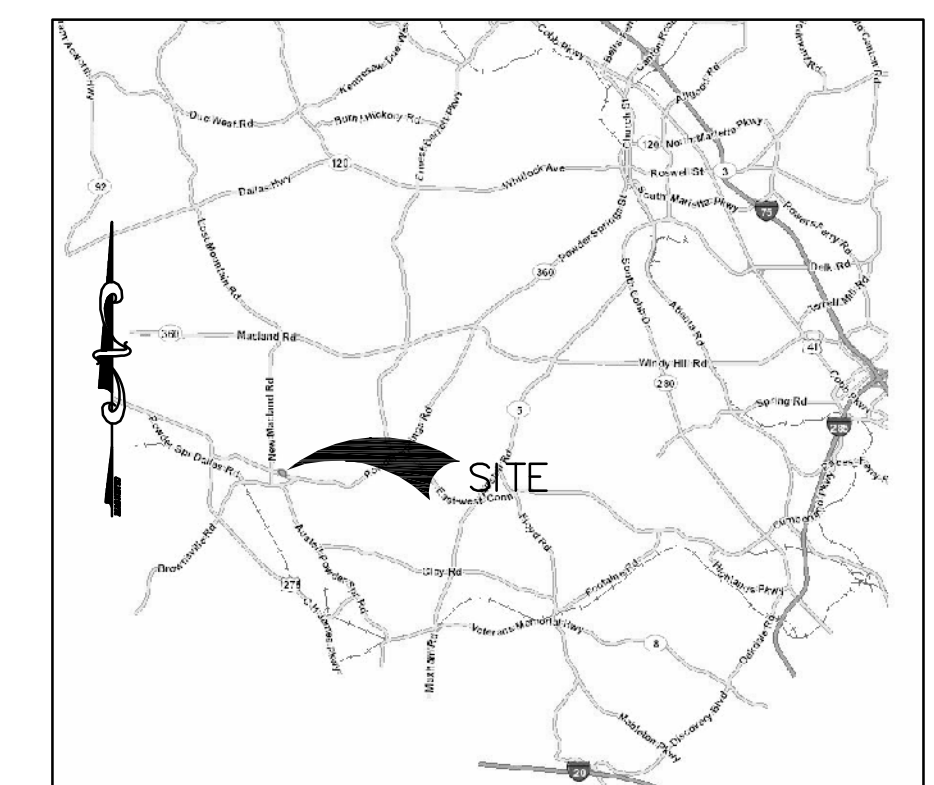
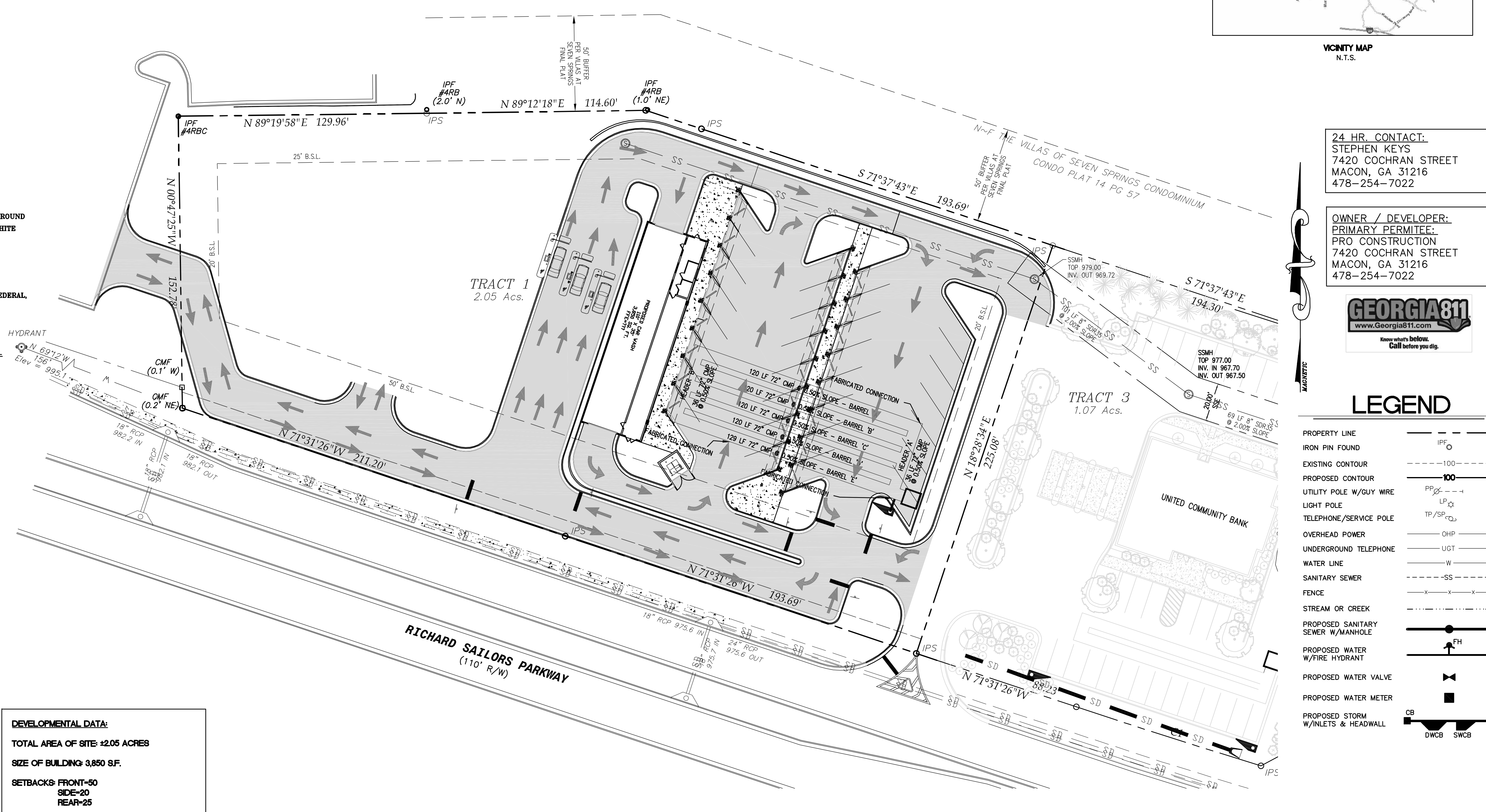
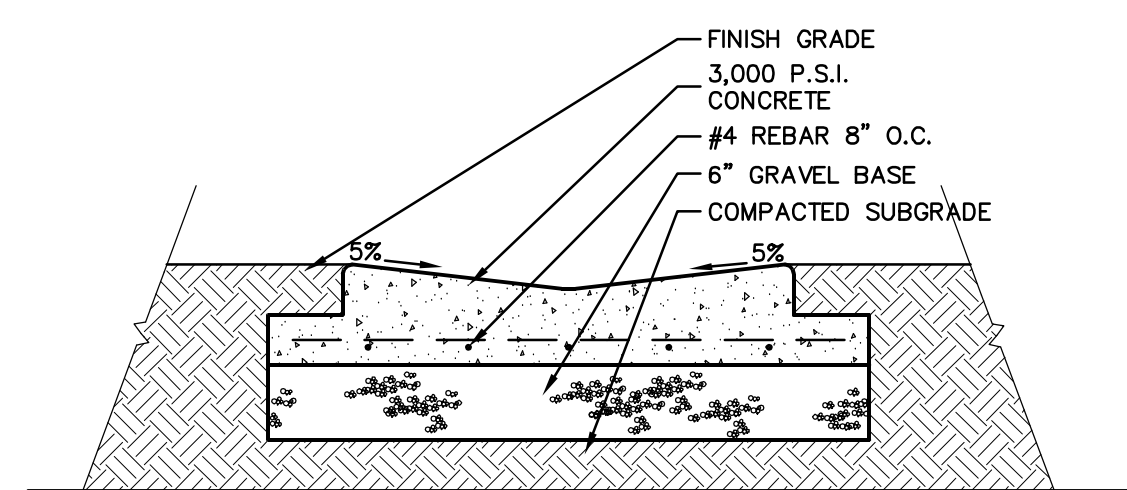
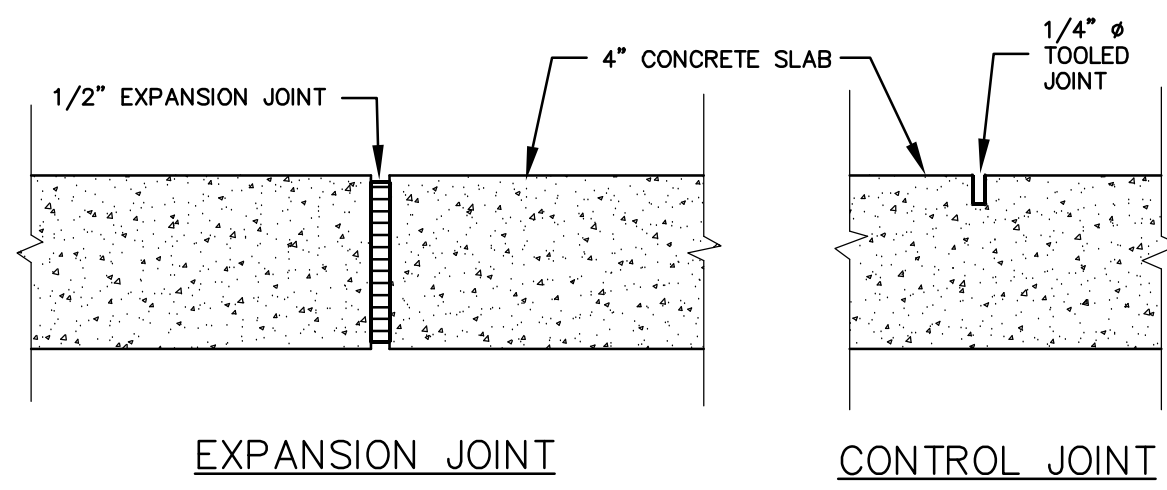

24 HR. CONTACT:  
STEPHEN KEYS  
7420 COCHRAN STREET  
MACON, GA 31216  
478-254-7022

OWNER / DEVELOPER:  
PRIMARY PERMITEE:  
PRO CONSTRUCTION  
7420 COCHRAN STREET  
MACON, GA 31216  
478-254-7022



LEGEND

- PROPERTY LINE
- IRON PIN FOUND
- EXISTING CONTOUR
- PROPOSED CONTOUR
- UTILITY POLE W/GUY WIRE
- LIGHT POLE
- TELEPHONE/SERVICE POLE
- OVERHEAD POWER
- UNDERGROUND TELEPHONE
- WATER LINE
- SANITARY SEWER
- FENCE
- STREAM OR CREEK
- PROPOSED SANITARY SEWER W/MANHOLE
- PROPOSED WATER W/FIRE HYDRANT
- PROPOSED WATER VALVE
- PROPOSED WATER METER
- PROPOSED STORM W/INLETS & HEADWALL

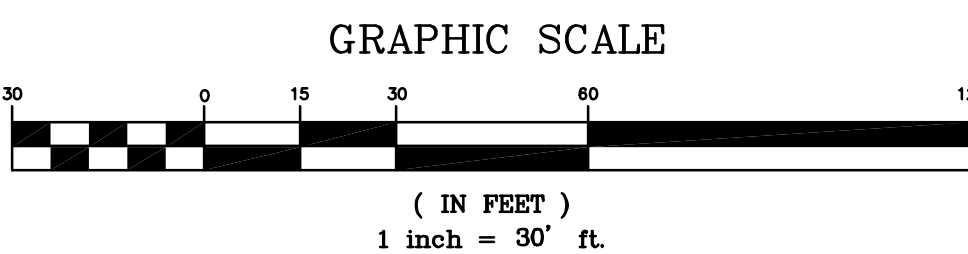

STAMP HERE FOR DEPARTMENT APPROVAL  
DRAWING NAME \_\_\_\_\_ DRAWING # \_\_\_\_\_

- REVISIONS:**
- 1.
  - 2.
  - 3.
  - 4.



LEVEL II CERTIFICATION  
GSWCC # 24610

THESE DOCUMENTS AS INSTRUMENTS OF SERVICE, REMAIN THE PROPERTY OF WIDNER & ASSOCIATES, AND NO PART THEREOF MAY BE USED OR REPRODUCED IN ANY FORM WITHOUT WRITTEN PERMISSION.

**Widner & Associates, Inc.**

24 HR. CONTACT:  
STEPHEN KEYS  
7420 COCHRAN STREET  
MACON, GA 31216  
478-254-7022

OWNER / DEVELOPER:  
PRIMARY PERMITEE:  
PRO CONSTRUCTION  
7420 COCHRAN STREET  
MACON, GA 31216  
478-254-7022

**GEORGIA811**  
www.Georgia811.com

SITE/STAKING PLAN FOR  
**PARADISE COVE CAR WASH**  
**1220 RICHARD D. SAILORS PKWY**  
POWDER SPRINGS, COBB COUNTY, GEORGIA  
LAND LOT (S) 872

DATE: 06/11/18  
DRAWN BY: JAP  
CHECKED BY: WTW  
PROJECT #: 9866-070-010

SHEET C-1  
SCALE: 1" = 30'  
APPROV. \_\_\_\_\_

\\Besserverector09\Projects\9866-070\Drawings\CD\9866-070.dwg and Tue, 03 July 2018 5:50pm