

DEVELOPMENT SUMMARY	
ZONING	NRC
EXISTING ZONING	PUD-R
PROPOSED ZONING	
AREA/DENSITY	22.37 ACRES
SITE AREA	123 UNITS
NUMBER OF UNITS	5.5 UNITS/ACRE
PROPOSED DENSITY	
SETBACKS	
FRONT	10 FEET
REAR	5 FEET
SIDE MAJOR	5 FEET
SIDE MINOR	10 FEET
PERIMETER	35 FEET
MAXIMUM BUILDING HEIGHT	35 FEET

NOTE: ALL UNITS TO BE SINGLE-FAMILY DETACHED HOMES. NO TOWNHOMES TO BE PROPOSED.

24 HOUR CONTACT:
JEFF SMITH
404.328.6280

VARIANCE SUMMARY	
1.	ALLOW DEAD END ROADS PER THIS SITE PLAN
2.	ALLOW A MINIMUM LOT SIZE OF 2,600 SF (PUD-R SECTION 2-15)
3.	VARIANCE TO ELIMINATE REQUIREMENT TO MAINTAIN 75% OF EXISTING TREE CANOPY (SECTION 12-1.3)
4.	VARIANCE TO ALLOW A MINIMUM HORIZONTAL ROAD CENTERLINE RADIUS OF 37 FEET
5.	ALLOW MORE THAN 8 ACRES TO BE CLEARED AT ONE TIME

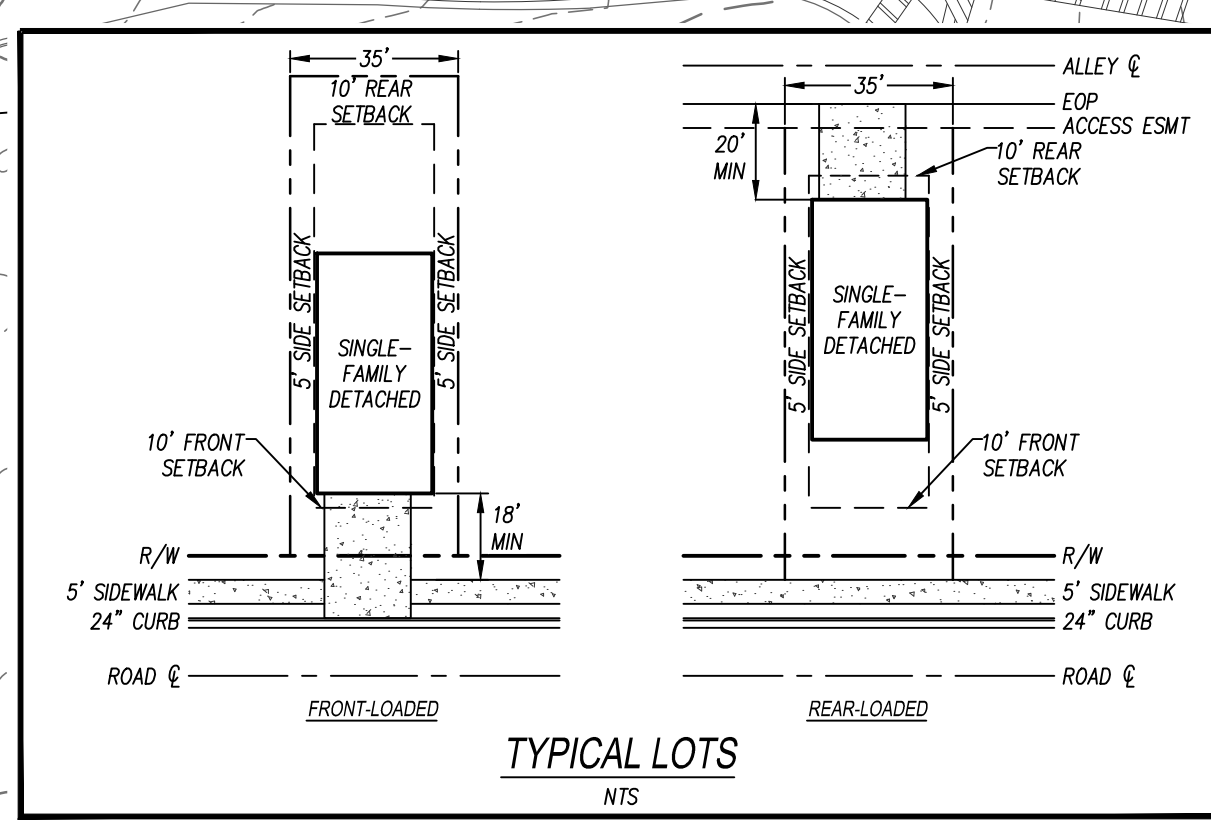
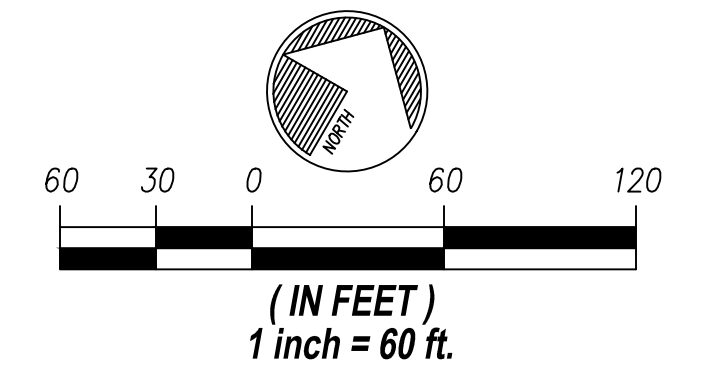

GEORGIA811
 Utilities Protection Center, Inc.

Know what's below. Call before you dig.

THE UTILITIES SHOWN HEREON ARE FOR THE CONTRACTORS CONVENIENCE ONLY. THERE MAY BE OTHER UTILITIES NOT SHOWN ON THESE PLANS. THE ENGINEER ASSUMES NO RESPONSIBILITY FOR THE LOCATIONS SHOWN AND IT SHALL BE THE CONTRACTOR'S RESPONSIBILITY TO VERIFY ALL UTILITIES WITHIN THE LIMITS OF THE WORK. ALL DAMAGE MADE TO EXISTING UTILITIES BY THE CONTRACTOR SHALL BE THE SOLE RESPONSIBILITY OF THE CONTRACTOR.

RIDGE PLANNING AND ENGINEERING®
 1290 KENNESAW AVENUE, BLDG A
 SUITE 200 - MARIETTA, GA 30066
 OFFICE 770.938.9000

ZONING PLAN
 HILL ROAD SUBDIVISION
 LAND LOTS 898 & 963
 19TH DISTRICT, 2ND SECTION
 POWDER SPRINGS, GEORGIA

OWNER/DEVELOPER

 TRATON HOMES
 720 KENNESAW AVE
 MARIETTA, GEORGIA 30060

GSWC CERTIFICATION NUMBER: 36629
 EXPIRATION DATE: 08.01.2018

REVISIONS
 3/26/21-REVISE FRONT SETBACK

ZONING PLAN
Z100

20068 Z100.DWG 2.25.2021
 Copyright © 2021